

OUTPUT FORMATS

Pentra  400

ABX **Pentra 400**

RAA025GEN

Table of contents

- > Physical connection, page 3
- > ASTM format, page 4
- > Contact, page 23

Revisions

Part number	Software version		Chapters	Date
	Pentra 400	Pentra C400		
RAA025GEN	5.0.7	1.1.X	All	08/07/13

Physical connection

RS232 connection

The RS port connector of the instrument is a standard DB-9 male connector.

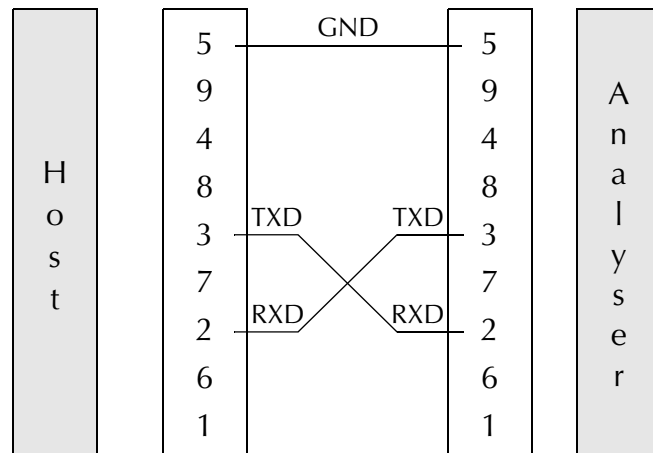

ASTM format

HORIBA Medical analyzer format complies with the ASTM specifications E-1381 & E-1394:

- E-1381: Standard specification for Low Level protocol to transfer messages between clinical or laboratory instruments and computer systems.
- E-1394: Standard specification for transferring Information between clinical or laboratory instruments and computer systems.

1. Connection specifications (ASTM E-1381)

1.1. Hardware and software characteristics

You can setup Baud rate, Parity, Stop bit,...

Hardware setting of the interface: Connect the Host and the instrument with the DB-9 serial port.

1.2. Output data characteristics

Characters: ASCII

Maximum message length: 247 characters including the control characters

Analyzer manages Xon/Xoff protocol.

1.3. Communication protocol

Table 1: Standard control characters

Control String	Hexadecimal value
<ENQ>	\$05
<ACK>	\$06
<NAK>	\$15
<STX>	\$02
<ETX>	\$03
<ETB>	\$17
<CR>	\$0D
<LF>	\$0A
<EOT>	\$04

1.3.1. Instrument/Host connection

Table 2: Typical discussion between Instrument and Host

Instrument	< >	Host
<ENQ>	>	
	<	<ACK>
<STX>1...Data...<CR><ETX>xx<CR><LF>	>	
	<	<ACK>
<STX>2...Data...<CR><ETX>xx<CR><LF>	>	
	<	<ACK>
<EOT>	>	

Table 3: Typical discussion between Host and Instrument

Instrument	< >	Host
	<	<ENQ>
<ACK>	>	
	<	<STX>1...Data...<CR><ETX>xx<CR><LF>
<ACK>	>	
	<	<STX>2...Data...<CR><ETX>xx<CR><LF>
<ACK>	>	
	<	<EOT>

1.3.2. Discussion with conflict between Instrument and Host

Number of transmissions if negative answer: 6

Timeout: 15s

Special timing: None

Description of other specific treatments: None

In case of ENQ/ENQ conflict, analyzer waits for 2s and tries emitting again, in case of 6 successive tries, analyzer will wait for 10s (default is 10s) before another downloading request.

Analyzer prevails in case of conflict.

Table 4: Discussion with conflict between Instrument and Host

Instrument	< >	Host
<ENQ>	>	
	<	<ENQ>
Waits for 2 seconds...		
<ENQ>	>	
	<	<ACK>

Table 4: Discussion with conflict between Instrument and Host

Instrument	< >	Host
<STX>1...Data...<CR><ETX>xx<CR><LF>	>	
	<	<ACK>
<STX>2...Data...<CR><ETX>xx<CR><LF>	>	
	<	<ACK>
<EOT>	>	

1.3.3. Defect packet during discussion between Instrument and Host

Table 5: Defect packet during discussion between Instrument and Host

Instrument	< >	Host
<ENQ>	>	
	<	<ACK>
<STX>1...Data...<CR><ETX>xx<CR><LF>	>	
	<	<NAK>
<STX>1...Data...<CR><ETX>xx<CR><LF>	>	
	<	<ACK>
<STX>2...Data...<CR><ETX>xx<CR><LF>	>	
	<	<ACK>
<EOT>	>	

1.3.4. Message length > 240 characters

If the data is longer than 240 characters, it must be split into two parts and sent in two communications packets. The intermediate packet uses the <ETB> character, and the ending packet uses the <ETX> character.

1.4. Flow control

Xon/Xoff protocol may be used on HORIBA Medical instruments.

1.5. Interruptions

If the emission of results is started, the EOT interruption character will not be taken into consideration.

On the other hand, if the EOT interruption character is received during the frame preceding the results, the analyzer will close its message by the terminal phase, then will wait for 20s before taking the line again.

1.6. ASTM Data frame format

A sequential number located after the <STX> character is inserted into each Data frame. Frame number is set to 1 when transfer phase is initialized and is incremented by 1 for each frame up to 7 and then returns to 0.

Frame number allows receiver to distinguish between new and retransmitted frame. In case of retransmitted frame (after a <NAK> response from Host), frame number is not incremented: <STX>1...Data...<CR><ETX>xx<CR><LF>.

Table 6: Frame format

ASTM field	Definition	Transmitted data	# of bytes	Comments
0	STX	\$02	1	
1	Frame number	1 to 7, 0,...	1	Frame number is set to 1 and incremented by 1 for each frame up to 7 and then returns to 0
2	Data message		240 max.	Header, Patient, Order, Result & Comment messages

Table 6: Frame format

ASTM field	Definition	Transmitted data	# of bytes	Comments
3	End of data message ETB if data message contains 240 characters ETX if end frame		1	
4	Checksum		2	
5	CRLF	\$0D \$0A	2	

1.6.1. Frame checksum

According to ASTM E-1381, frame checksum (<STX>1...Data...<CR><ETX>xx<CR><LF>) is defined as modulo 256 of ASCII values sum between <STX> not included and <ETX> included characters: 1...Data...<CR><ETX>.

2. Record general format specifications (ASTM E-1394)

2.1. Codes of characters

HORIBA Medical analyzers use Standard ASCII characters set with codes between 32 and 127 (codes from 0 to 31 are for protocol only).

The Escape delimiter is not used in the data sent by analyzers.

Data frames encapsulate Records defined by ASTM E-1394 norm, Records themselves encapsulate ASTM fields.

The record is inside Data frame: <STX>1...Data...<CR><ETX>xx<CR><LF>

Table 7: ASTM Records

Record ID	ASTM Definition
H	Header
P	Patient
O	Order
R	Result
C	Comment
Q	Query (Request information order)
S	Scientific record
M	Manufacturer information
L	Terminator record

2.2. Structure of Records

2.2.1. Structure of records for Order transmission

The transmission of an Order without Patient record is not allowed, but Patient record can be empty. Example: <STX>2P|1<CR><ETX>BB<CR><LF>.

The modification of a Patient is allowed only if the corresponding "Patient file" is not in process.

2.2.1.1. Unique Order record

- H (Header)
- ..P (Patient)
- ..C (Patient Comments) Optional
-O (Order)
-C (Order Comments) Optional
- L (Terminator)

2.2.1.2. Multi Order record

- H (Header)
- ..P (Patient)
- ..C (Patient Comments) Optional
-O (Order)
-O (Order)
-O (Order)
-C (Order Comments) Optional
- L (Terminator)

2.2.2. Structure of records for Result transmission

- H (Header)
- ..P (Patient)
- ..C (Patient Comments) Optional
-O (Order)
-C (Order Comments) Optional
-C (Run Alarms) Optional
-R (Result)
-C (Flag Result) Optional
-R (Result)
-C (Flag Result) Optional
-
-
-R (Result)
-C (Flag Result) Optional
- L (Terminator)

2.3. Description of Records

- Delimiter must be used even if field is free.
- Delimiters inside records are separated by "|" (ASCII \$7C).
- Delimiters inside fields are separated by "^" (ASCII \$5E).

2.3.1. Header record

R = Received by the instrument from the Host
 S = Sent by the instrument to the Host

Table 8: Header record fields

ASTM field	Definition	Transmitted data	Used for		Field length
			R	S	
7.1.1	Record Type	H	✓	✓	1
7.1.2	Delimiters definition	idem standard	✓	✓	4
7.1.3	Message Control ID				
7.1.4	Access Password				
7.1.5	Sender Name	Text		✓	15
7.1.6	Sender Address				
7.1.7	Reserved				
7.1.8	Sender Telephone Nb				
7.1.9	Characteristics of Sender				
7.1.10	Receiver ID				
7.1.11	Comments or Special Instructions				
7.1.12	Processing ID	P (=patient), Q (=control)		✓	1
7.1.13	Version Nb	E1394-97		✓	8
7.1.14	Date and Time of message	YYYYMMDDHHMMSS		✓	14

2.3.2. Patient record

Table 9: Patient record fields

ASTM field	Definition	Transmitted data	Used for		Field length
			R	S	
8.1.1	Record Type	P	✓	✓	1
8.1.2	Sequence Nb	1, 2, 3...	✓	✓	1
8.1.3	Practice Assigned Patient ID				
8.1.4	Laboratory Assigned Patient ID	Patient ID (Advised for Workflow management) The Space character is banned on the left and on the right of the text.	✓	✓	25
8.1.5	Patient ID No 3				
8.1.6	Patient Name	LASTNAME^FIRSTNAME	✓	✓	20^20
8.1.7	Mother's Maiden Name				
8.1.8	Birthdate	YYYYMMDD	✓	✓	8
8.1.9	Patient Sex	M (male), F (female) or U (unspecified)	✓	✓	1
8.1.10	Patient Race-Ethnic Origin				
8.1.11	Patient Address				
8.1.12	Reserved				
8.1.13	Patient Telephone Nb				
8.1.14	Attending Physician ID	Text	✓		20
8.1.15	Special Field 1				
8.1.16	Special Field 2				
8.1.17	Patient Height				
8.1.18	Patient Weight				

Table 9: Patient record fields

ASTM field	Definition	Transmitted data	Used for		Field length
			R	S	
8.1.19	Patient's Known or Suspected Diagnosis				
8.1.20	Patient Active Medication				
8.1.21	Patient's Diet				
8.1.22	Practice Field 1				
8.1.23	Practice Field 2				
8.1.24	Admission and Discharge Dates				
8.1.25	Admission Status				
8.1.26	Location	Text	✓		20
8.1.27	Nature of Alternative Diagnostic Code and Classifiers				
8.1.28	Nature of Alternative Diagnostic Code and Classifiers				
8.1.29	Patient Religion				
8.1.30	Marital Status				
8.1.31	Isolation Status				
8.1.32	Language				
8.1.33	Hospital Service				
8.1.34	Hospital Institution				
8.1.35	Dosage Category				

The fields above are filled in following the demographic level of information present on the analyzer.

2.3.3. Order record

Table 10: Order record fields

ASTM field	Definition	Transmitted data	Used for		Field length
			R	S	
9.4.1	Record Type	O	✓	✓	1
9.4.2	Sequence Nb	1, 2, 3...	✓	✓	1
9.4.3	Specimen ID	Sample ID	✓		16
		Sample ID [^] rack [^] pos [^] repl cate		✓	16+2+2+2
		"CONTROL" [^] rack [^] pos [^] repl cate [^] Control Name [^] Lot N ^o		✓	7+2+2+2+20+ 16
The Space character is banned on the left and on the right of the text.					
9.4.4	Instrument Specimen ID				
9.4.5	Universal Test ID	^^^Test code\^^^Test code... (from the Host) or empty from Pentra	✓		see Table 12, "Test codes", page 12
9.4.6	Priority	S (Stat) or R (Routine)	✓		1
9.4.7	Requested/Ordered Date and Time			✓	14
9.4.8	Specimen Collection Date and Time	YYYYMMDDHHMMSS	✓	✓	14
9.4.9	Collection End Time				
9.4.10	Collection Volume				
9.4.11	Collector ID				

Table 10: Order record fields

ASTM field	Definition	Transmitted data	Used for		Field length
			R	S	
9.4.12	Action Code (see nota)	C: Cancel request N: New request A: Add request Q: Send a control	✓		1 mandatory for reception (C/A/N)
9.4.13	Danger Code				
9.4.14	Relevant Clinical Information				
9.4.15	Date/Time Specimen Received				
9.4.16	Specimen Descriptor	1: Serum/Plasma 2: Urine 3: Other (see Table 12, "Test codes", page 12) Empty if control	✓	✓	1 (mandatory)
9.4.17	Ordering Physician			✓	20
9.4.18	Physician Tel Nb				
9.4.19	User Field 1				
9.4.20	User Field 2				
9.4.21	Laboratory Field 1				
9.4.22	Laboratory Field 2				
9.4.23	Date and Time Results reported or last modified				
9.4.24	Instrument Charge to Computer System				
9.4.25	Instrument Section ID				
9.4.26	Report Types	F: Final		✓	1
9.4.27	Reserved				

Table 10: Order record fields

ASTM field	Definition	Transmitted data	Used for		Field length
			R	S	
9.4.28	Location or Ward of Specimen Collection				
9.4.29	Nosocomial Infection Flag				
9.4.30	Specimen Service			✓	20
9.4.31	Specimen Institution				



If the Action Code (field 9.4.12) is "A" for the first download, the order is created on the instrument.
In case of a Multi Order record, "N" must be used for the first Order and "A" for the next Orders. Otherwise, only the first Order will be taken into account.

2.3.4. Result record

Table 11: Result record fields

ASTM field	Definition	Transmitted data	Used for		Field length
			R	S	
10.1.1	Record Type	R		✓	1
10.1.2	Sequence Nb	1, 2, 3...		✓	1
10.1.3	Universal Test ID*	^^^Test code ^ Test Name		✓	see Table 12, "Test codes", page 12
10.1.4	Data or Measurement Value	Text xxx.xxx		✓	Max 11
10.1.5	Units	see Table 17, "Units", page 15		✓	2
10.1.6	Reference Range	Normal L to Normal H Panic L to Panic H			
10.1.7	Result Abnormal Flag	L, H, A		✓	2

Table 11: Result record fields

ASTM field	Definition	Transmitted data	Used for		Field length
			R	S	
10.1.8	Nature of Abnormality Testing				
10.1.9	Result Status	M: Operator Modified F: Final result		✓	1
10.1.10	Date of Change in Normative Values or Units				
10.1.11	Operator Identification				
10.1.12	Date/Time Test Starting	YYYYMMDDHHMMSS		✓	14
10.1.13	Date/Time Test Completed				
10.1.14	Instrument Identification				

The transmitted numerical values correspond to the rounded values displayed on the analyzers, therefore they never exceed 6 characters.

The transmitted units are the ones configured by the user.

*: The Test codes table should be updated on the Host according to the test definition, for the Open Channels, freely definable by the user. The Test codes available on the instrument are between 000 and 999. The calculated parameters available on the instrument are from 1000.

Example of calculated parameter: if Test Name "Ratio" = APO A1 / APO B (Test code 1001), the LIS only have to send the test code 1001 in the field 9.4.5 of the Order record to receive results for "Ratio" with APO A1 and APO B parameters.

The relation between "Test Name" and "Specimen" should be in accordance with the table below (only the orders created with the right relation will be accepted in the worklist).

Table 12: Test codes

Test Code	Test Name	Specimen	Test Code	Test Name	Specimen	Test Code	Test Name	Specimen
1			26	GluP-U	2	51		
2			27	GluK	1	52	HAPT	1
3	ALP_R	1	28			53	A1c-WB	3
4	ALT	1	29	Iron	1	54	A1c-H	3
5	AST	1	30	Lact	1	55	THb-WB	3
6	Amy	1	31	Magn	1	56	THb-H	3
7	Amy-U	2	32	Phos	1	57		
8	CK	1	33	Phos-U	2	58		
9	CKMB	1	34	TP	1	59		
10	GGT	1	35	TPU	2	60	Kappa	1
11			36	Trigly	1	61	Lambda	1
12	Lipase	1	37	UA	1	62		
13	Alb	1	38	UA-U	2	63		
14	Bili-T	1	39	Urea	1	64	Oroso	1
15	Bili-D	1	40	Urea-U	2	65	Prealb	1
16	Calcium	1	41			66	RF	1
17	Calc-U	2	42	Alb-T	1	67		
18	C_Chol	1	43	μALB-U	2	68		
19	C_HDL	1	44	Apo A1	1	69		
20	C_LDL	1	45	Apo B	1	70		
21	CO2	1	46	ASO	1	71		
22			47			72		
23			48			73		
24	Fructo	1	49			74	BUN-U	2
25	GluP	1	50	CRP	1	75		

Table 12: Test codes

Test Code	Test Name	Specimen	Test Code	Test Name	Specimen	Test Code	Test Name	Specimen
76			101	NA_S	1	217	CREA_RB	1
77	BUN	1	102	K_S	1	218	Chol_AK	1
78	ALPM_R	1	103	CL_U	2	219	AlbT	1
79	TP_R	1	104	NA_U	2	220	AlbT-U	2
80	CA_R	1	105	K_U	2	.../...		
81	CA_R U	2	106					
82	LDH	1	107					
83	FERR2	1	.../...					
84			152	GluHK-U	2			
85			.../...					
86			202					
87	MYO2	1	203					
88			204	TP2	1			
89			205	LDHifcc	1			
90			206					
91			207					
92	IgA_CP	1	208					
93	IgG_CP	1	209	Crenz	1			
94	IgM_CP	1	210	Crenz-U	2			
95	TRSF_CP	1	211	CREA3	1			
96			212	CREA_U3	2			
97			213	TP3	1			
98			214	HDL100	1			
99			215	CaAS	1	.../...		
100	CL_S	1	216	CaU_AS	2	600	T1	1



The table above is given as an example and should be updated on the Host with the Application Version installed on the instrument. Please refer to the Application Version Release Note.
ISE Test codes (from 100 to 105) are never affected by an Application Version update.

2.3.5. Terminator record

Table 13: Terminator record

ASTM field	Definition	Transmitted data	Field length
13.1.1	Record type	L	1
13.1.2	Sequence number	1	1
13.1.3	Termination code	N: Normal I: No information available for last query	1

2.3.6. Flags and alarms



Please refer to the instrument user manual for a complete description of analytical and quality flags.

2.3.6.1. Analytical alarms

All the results with an analytical flag are identified and transmitted the following way:

- "A" for Abnormal in the field 10.1.7 of the result.
- The result record is followed by a comment record. All the flags, separated by a delimiter (^), are in this comment record.

Table 14: Analytical flags

Flags
HIGH_ABS
SAMPLE_LIMIT
(1)REAG_RANGEHIGH (2)REAG_RANGELOW
NON_LINEAR_A NON_LINEAR_B NON_LINEAR_C NON_LINEAR_D
HIGH_ACTIV
REAC_LIMIT_A REAC_LIMIT_B REAC_LIMIT_C REAC_LIMIT_D
NOISE_A NOISE_B NOISE_C NOISE_D
AG_EXCESS
BLANK_RANGE
SIGN
DIV_ABS_A DIV_ABS_B DIV_ABS_C DIV_ABS_D
DIV_ABSf_A DIV_ABSf_B DIV_ABSf_C DIV_ABSf_D

Table 14: Analytical flags

Flags
DIV_ABSi_A
DIV_ABSi_B
DIV_ABSi_C
DIV_ABSi_D
(1)TEST_RANGE_LOW
(2)TEST_RANGE_HIGH
CALC_CONCENTRATION
DEVIATION
(1)LINEARITY_LOW
(2)LINEARITY_HIGH
(1)CONF_RANGELOW
(2)CONF_RANGEHIGH
(1)CONF_RANGELOW_W
(2)CONF_RANGEHIGH_W
(1)CONF_RANGELOW_W1
(2)CONF_RANGEHIGH_W1
(1)CONF_RANGELOW_W2
(2)CONF_RANGEHIGH_W2
(1)CONF_RANGELOW_W3
(2)CONF_RANGEHIGH_W3
(1)CONF_RANGELOW_W4
(2)CONF_RANGEHIGH_W4
(1)CONF_RANGELOW_W5
(2)CONF_RANGEHIGH_W5
(1)CONF_RANGELOW_W6
(2)CONF_RANGEHIGH_W6
WESTGARD_RULE_4
WESTGARD_RULE_5
WESTGARD_RULE_6

Table 14: Analytical flags

Flags
(1)CRITICAL_RANGEL
(2)CRITICAL_RANGEH
(1)NORM_RANGEL
(2)NORM_RANGEH
(1)CALC_RANGELOW
(2)CALC_RANGEHIGH
ISE_ERROR

Table 15: Quality flags

Message	Flags
R	CALC_CONV
C	CALC_ERROR
Q	CTRL_ERROR
KE	CALIBRATION_EXPIRED
CE	CAL_EXPIRED
QE	CTRL_EXPIRED
SE	SOL_EXPIRED
I	INCOMPATIBILITY

2.3.6.2. Biological flags

All the results with a biological flag are identified and transmitted the following way:

The field 10.1.7 of the result record is filled in with one of those identifiers: "L / H".

2.3.7. Comment record

Table 16: Comment record fields

ASTM field	Definition	Transmitted data	Used for		Field length
			R	S	
11.1.1	Record Type	C	✓	✓	1
11.1.2	Sequence Nb	1, 2, 3...	✓	✓	1
11.1.3	Comment Source	I: Clinical instrument system		✓	1
11.1.4	Comment Text	Text	✓	✓	Comment Text dependent
11.1.5	Comment Type	G: Free text I: Instrument flag comment		✓	1

2.3.8. Units

Units are transmitted in the field 10.1.5 of the result record.

Table 17: Units

	Units		Units		Units
1	Ref	17	µg/dL	33	IU/dL
2	mol/L	18	ng/L	34	mIU/L
3	mol/dL	19	ng/dL	35	mIU/dL
4	mmol/L	20	mg/mL	36	mIU/mL
5	mmol/dL	21	µg/mL	37	mval/L
6	µmol/L	22	ng/mL	38	mEq/L
7	µmol/dL	23	pg/mL	39	%
8	nmol/L	24	µkat/L	40	s
9	nmol/dL	25	nkat/L	41	KU/L

Table 17: Units

	Units		Units		Units
10	pmol/L	26	U/L	42	kIU/L
11	pmol/dL	27	U/dL	43	g/mol
12	g/L	28	mU/L	44	mg/g
13	g/dL	29	mU/dL	45	Δ A
14	mg/L	30	U/mL	46	Δ A/min
15	mg/dL	31	mU/mL	47	Δ %
16	µg/L	32	IU/L	48	IU/mL

2.3.9. QUERY mode

The E-1394 protocol imposes a specific treatment for the request to the LIS. The characteristics of this treatment are as follows.

2.3.9.1. Emission of a request to the LIS

Table 18: Request information record fields

ASTM field	Definition	Transmitted data	Used for		Field length
			R	S	
12.1.1	Record Type	Q	✓	✓	1
12.1.2	Sequence Nb	1	✓	✓	1
12.1.3	Starting Range ID Number	^SID	✓	✓	1+16
12.1.4	Ending Range ID Number				
12.1.5	Universal Test ID	All		✓	
12.1.6	Nature of Request Time Limits				
12.1.7	Beginning Request Result Date & Time				

Table 18: Request information record fields

ASTM field	Definition	Transmitted data	Used for		Field length
			R	S	
12.1.8	Ending Request Result Date & Time				
12.1.9	Requesting Physician Name				
12.1.10	Requesting Physician Tel N°				
12.1.11	User Field 1				
12.1.12	User Field 2				
12.1.13	Request Information Status code	O: Test information and demographic request (no results) X: Request cancelled	✓	✓	

2.3.9.2. Test order on request reception

- Query messages are generated by the instrument at each Barcode reading cycle for tubes unknown in the worklist.

- A Query message consists of the sequence H, Q, L. The Q record contains 1 SID.

- For each Query message, a response from the Host is expected. If the response is not received after a delay of 10 seconds, the instrument will not try to send another Query message.

- There are 3 cases of response returned by the Host (see Table 19, "Example: tube 2312019", page 16 which is a description of case 1 and case 2):

1. An order is matched for the SID: The response message consists of the following sequence of records H, P, O, L.

2. There is no order matched for the SID: The response message consists of the sequence of records: H, Q, L with "X" for the field 12.1.13 (Request Information Status code).

3. There is no order matched for the SID: The response message consists of the sequence of records: H, L with "I" for the field 13.1.3 (Termination code). In this case, the instrument will not try to send another Query message.

The color of the line defines the transmission way:

- From HOST to PENTRA
- From PENTRA to HOST

Table 19: Example: tube 2312019

Query for the tube 2312019
<ENQ>
<ACK>
<STX>1H ^& P E1394-97 20050111111131<CR><ETX>6A<CR><LF>
<ACK>
<STX>2Q 1 ^2312019 ALL 0<CR><ETX>7C<CR><LF>
<ACK>
<STX>3L 1 N<CR><ETX>06<CR><LF>
<ACK>
<EOT>
Answer for the tube 2312019 (with programming) - Routine Mode
<ENQ>
<ACK>
<STX>1H ^& ABX P E1394-97 200501111111502<CR><ETX>47<CR><LF>
<ACK>
<STX>2P 1 PID001 NAME^FIRSTNAME 19641223 M PRESCRIPATOR LOCATION
<CR><ETX>14<CR><LF>
<ACK>
<STX>3C 1 PATIENT COMMENT <CR><ETX>38<CR><LF>
<ACK>

Table 19: Example: tube 2312019

```

<STX>40|1|2312019||^13^^12^^14^^32^^34^^37^^39|R|19900522105500||
|A|||1<CR><ETX>4F<CR><LF>
<ACK>
<STX>5C|1||ORDER COMMENT<CR><ETX>A1<CR><LF>
<ACK>
<STX>6L|1|N<CR><ETX>09<CR><LF>
<ACK>
<EOT>
Answer for the tube 2312019 (with programming) - STAT Mode
<ENQ>
<ACK>
<STX>1H|^&||ABX||||P|E1394-97|20050111111502<CR><ETX>47<CR><LF>
<ACK>
<STX>2P|1||PID001||NAME^FIRSTNAME||19641223|M||||PRESCRIPTOR|||||||LOCATION
<CR><ETX>14<CR><LF>
<ACK>
<STX>3C|1||PATIENT COMMENT|<CR><ETX>38<CR><LF>
<ACK>
<STX>40|1|2312019||^13^^12^^14^^32^^34^^37^^39|S|19900522105500||
|A|||1<CR><ETX>4F<CR><LF>
<ACK>
<STX>5C|1||ORDER COMMENT<CR><ETX>A1<CR><LF>
<ACK>
<STX>6L|1|N<CR><ETX>09<CR><LF>
<ACK>
<EOT>

```

Table 19: Example: tube 2312019

```

Answer for the tube 2312019 (with programming) - Multi Order record
<ENQ>
<ACK>
<STX>1H|^&||ABX||||P|E1394-97|20050111111131<CR><ETX>45<CR><LF>
<ACK>
<STX>2P|1||PID001||NAME^FIRSTNAME||19641223|M||||PRESCRIPTOR|||||||LOCATION<CR><
ETX>14<CR><LF>
<ACK>
<STX>3C|1||PATIENT COMMENT|<CR><ETX>38<CR><LF>
<ACK>
<STX>40|1|2312019||^136|R|19900522105500||||N|||1<CR><ETX>85<CR><LF>
<ACK>
<STX>50|2|2312019||^120|R|19900522105500||||A|||1<CR><ETX>73<CR><LF>
<ACK>
<STX>60|3|2312019||^119|R|19900522105500||||A|||1<CR><ETX>7D<CR><LF>
<ACK>
<STX>70|4|2312019||^118|R|19900522105500||||A|||1<CR><ETX>7E<CR><LF>
<ACK>
<STX>0C|1||ORDER COMMENT<CR><ETX>20<CR><LF>
<ACK>
<STX>1L|1|N<CR><ETX>04<CR><LF>
<ACK>
<EOT>

```

Table 19: Example: tube 2312019

Answer for the tube 2312019 (with programming) - Message length > 240 characters
<ENQ>
<ACK>
<STX>1H ^& ABX P E1394-97 20121003082008<CR><ETX>4E<CR><LF>
<ACK>
<STX>2P 1 PID001 NAME^FIRSTNAME 19641223 M PRESCRIPTOR LOCATION<CR><ETX>14<CR><LF>
<ACK>
<STX>3O 1 2312019 ^36^37^38^39^40^41^42^43^44^45^^46^^47^^48^^49^^50^^51^^52^^53^^54^^55^^56^^57^^58^^59^^60^^61^^62^^63^^64^^65^^66^^67^^68^^69^^70^^71^^72^^73<ETB>ED<CR><LF>
<ACK>
<STX>4^^74 R 19900522105500 N 1<CR><ETX>11<CR><LF>
<ACK>
<STX>5L 1 N<CR><ETX>08<CR><LF>
<ACK>
<EOT>
Answer for the tube 2312019 (without programming)
<ENQ>
<ACK>
<STX>1H ^& ABX P E1394-97 20050111111502<CR><ETX>47<CR><LF>
<ACK>
<STX>2Q 1 ^2312019 X<CR><ETX>AC<CR><LF>
<ACK>
<STX>3L 1 N<CR><ETX>06<CR><LF>
<ACK>
<EOT>

3. Management of errors

3.1. Field acceptance

- Only the fields described with their specified length, in previous tables, are used by HORIBA Medical instruments.
- Length of field can be inferior to maximum value but must not be superior.
- Only "Sample ID", "Action Code", "Specimen Descriptor" and "Test" fields from Order record must be filled in, all other fields are optional.
- If the length of the "Sample ID" is longer than the one defined in the order (see Table 10, "Order record fields", page 10, 9.4.3 field), the request is rejected.
- Concerning the "Sample ID", if there is space character on the left and on the right of the text or if the field is too long, the request is rejected.
- Concerning the "Patient ID", if there is space character on the left and on the right of the text or if the field is too long, the request is accepted but the "Patient Demographics" will be rejected.
- Concerning the "First Name", "Last Name", "Department" and "Physician" fields, the space characters on the left, on the right and all the characters beyond the defined value (20 characters) are deleted.

3.2. During Instrument transmission

During a single result transmission by the instrument, if the Host loses the transmission (Time-Out or EOT) the full message will be transmitted again after a configurable delay (10s by default).

In case of long files with several results the re-transmission will be done from the lost result until the end.

After 6 consecutive NAKs detected, the sent file is postponed until later transmission.

3.3. During Host transmission

According to E-1381 protocol, error management of Time-out, Checksum and frame number, in case of failure to comply with these norms, will return NAK (or communication will be halted). In case of transmission of long files (Worklist upload for example), files previously transmitted before transmission error will be interpreted and managed by the instrument, others will not be used.

According to E-1394 protocol, all Orders without "Sample ID" or with "Sample ID" superior to 16 characters, will not be interpreted by the instrument.

4. Example of data frame

4.1. Example of Test Order sent by Host

The color of the line defines the transmission way:

From HOST to PENTRA

From PENTRA to HOST

Table 20: Example of Test Order sent by Host

Routine Mode
<ENQ>
<ACK>
<STX>1H ^& ABX P E1394-97 20031118154840<CR><ETX>59<CR><LF>
<ACK>
<STX>2P 1 PID12345 LASTNAME^FIRSTNAME 19641223 M Prescriptor Location<CR><ETX>D6<CR><LF>
<ACK>
<STX>3C 1 Patient Comment <CR><ETX>B8<CR><LF>
<ACK>
<STX>4O 1 2312015 ^13^29 R 20031117 N 1<CR><ETX>25<CR><LF>
<ACK>
<STX>5C 1 Order Comment <CR><ETX>E1<CR><LF>
<ACK>
<STX>6L 1 N<CR><ETX>09<CR><LF>
<ACK>
<EOT>

Table 20: Example of Test Order sent by Host

STAT Mode
<ENQ>
<ACK>
<STX>1H ^& ABX P E1394-97 20050111111502<CR><ETX>47<CR><LF>
<ACK>
<STX>2P 1 PID001 NAME^FIRSTNAME 19641223 M PRESCRIPTOR LOCATION<CR><ETX>14<CR><LF>
<ACK>
<STX>3C 1 PATIENT COMMENT <CR><ETX>38<CR><LF>
<ACK>
<STX>40 1 2312019 ^13^^12^^14^^32^^34^^37^^39 S 19900522105500 A 1<CR><ETX>4F<CR><LF>
<ACK>
<STX>5C 1 ORDER COMMENT<CR><ETX>A1<CR><LF>
<ACK>
<STX>6L 1 N<CR><ETX>09<CR><LF>
<ACK>
<EOT>
Multi Order record
<ENQ>
<ACK>
<STX>1H ^& ABX P E1394-97 20050111111131<CR><ETX>45<CR><LF>
<ACK>
<STX>2P 1 PID001 NAME^FIRSTNAME 19641223 M PRESCRIPTOR LOCATION<CR><ETX>14<CR><LF>
<ACK>
<STX>3C 1 PATIENT COMMENT <CR><ETX>38<CR><LF>
<ACK>

Table 20: Example of Test Order sent by Host

<STX>4O 1 2312019 ^36 R 19900522105500 N 1<CR><ETX>85<CR><LF>
<ACK>
<STX>5O 2 2312019 ^20 R 19900522105500 A 1<CR><ETX>73<CR><LF>
<ACK>
<STX>6O 3 2312019 ^19 R 19900522105500 A 1<CR><ETX>7D<CR><LF>
<ACK>
<STX>7O 4 2312019 ^18 R 19900522105500 A 1<CR><ETX>7E<CR><LF>
<ACK>
<STX>0C 1 ORDER COMMENT<CR><ETX>20<CR><LF>
<ACK>
<STX>1L 1 N<CR><ETX>04<CR><LF>
<ACK>
<EOT>
Message length > 240 characters
<ENQ>
<ACK>
<STX>1H ^& ABX P E1394-97 20121003082008<CR><ETX>4E<CR><LF>
<ACK>
<STX>2P 1 PID001 NAME^FIRSTNAME 19641223 M PRESCRIPTOR LOCATION<CR><ETX>14<CR><LF>
<ACK>
<STX>3O 1 2312019 ^36^^37^^38^^39^^40^^41^^42^^43^^44^^45^^46^^47^^48^^49^^50^^51^^52^^53^^54^^55^^56^^57^^58^^59^^60^^61^^62^^63^^64^^65^^66^^67^^68^^69^^70^^71^^72^^73<ETB>ED<CR><LF>
<ACK>
<STX>4^74 R 19900522105500 N 1<CR><ETX>11<CR><LF>
<ACK>

Table 20: Example of Test Order sent by Host

```
<STX>5L|1|N<CR><ETX>08<CR><LF>
<ACK>
<EOT>
```



A test requested by the Host is created only if the corresponding test application is activated (whatever the reagent status is).

4.2. Example of Test Result sent by instrument

The color of the line defines the transmission way:

From HOST to PENTRA
From PENTRA to HOST

Table 21: Example of Test Result sent by instrument

```
<ENQ>
<ACK>
<STX>1H|^&|||||01|||||P|E1394-97|20031118162410<CR><ETX>D7<CR><LF>
<ACK>
<STX>2P|1||PID12345||LASTNAME^FIRSTNAME||19641223|M<CR><ETX>C4<CR><LF>
<ACK>
<STX>3C|1||Patient Comment|G<CR><ETX>FF<CR><LF>
<ACK>
<STX>4O|1|2312015|||||20031118154703|20031117000000|||||1|Prescriptor|||||F|||||Location<CR>
<ETX>EE<CR><LF>
<ACK>
<STX>5C|1||Order Comment|G<CR><ETX>28<CR><LF>
```

Table 21: Example of Test Result sent by instrument

```
<ACK>
<STX>6R|1|^1002^RATIO|5.54|2||A||F||1899123000000<CR><ETX>1D<CR><LF>
<ACK>
<STX>7C|1||Flag^NORM_RANGE|<CR><ETX>69<CR><LF>
<ACK>
<STX>0R|2|^13^ALB|5.5494|6||H||F||20031118162203<CR><ETX>7E<CR><LF>
<ACK>
<STX>1C|1||Flag^NORM_RANGEH|<CR><ETX>5F<CR><LF>
<ACK>
<STX>2R|3|^29^IRON1|-0.01262|6||L||F||20031118162215<CR><ETX>76<CR><LF>
<ACK>
<STX>3C|1||Flag^NORM_RANGE|<CR><ETX>65<CR><LF>
<ACK>
<STX>4L|1|N<CR><ETX>07<CR><LF>
<ACK>
<EOT>
```

4.3. Example of Control Header sent by instrument

```
HI \^&IIIP400-162IIIIIIQIE1394-97I20061013171336
```

4.4. Example of Control Order sent by Host

```
OI1CONTROL^^^N ctr^501500IIII20061010094849IIIIIIIIIIIF
```

4.5. Example of Control Result sent by instrument

The color of the line defines the transmission way:

From HOST to PENTRA

From PENTRA to HOST

Table 22: Example of Control Result sent by instrument

```
<STX>1HI \^&IIIP400-162IIIIIIQIE1394-97I20061013154745<CR><ETX>2A<CR><LF>  
<ACK>  
<STX>2PI1<CR><ETX>3F<CR><LF>  
<ACK>  
<STX>3OI1ICONTROL^^^Nctr^501500IIII20061010094849IIIIIIQIIIIIIIIIF<CR><ETX>1B<CR>  
<LF>  
<ACK>  
<STX>4RI1I^^18^C_Choll2.47I4IIIIIFIIII20061013154049<CR><ETX>2D<CR><LF>  
<ACK>  
<STX>5LI1IN<CR><ETX>08<CR><LF>
```

Contact

HORIBA ABX SAS

Parc Euromédecine - Rue du Caducée

B.P. 7290

34184 MONTPELLIER Cedex 4 - FRANCE

Phone: +33 (0)4 67 14 15 16

Fax: +33 (0)4 67 14 15 17

Online: <http://www.horiba.com/medical/>

